



CHARTING

WHY DO WE NEED TO CHART?

Charting is promoted because it gives the teacher and students a visual picture of how the student is learning . The chart aids the teacher in making more precise decisions about the student's learning. If the student is not learning or improving the chart signals that difficulty right away. There is no guesswork involved. Precision Teaching should not be used without the charting. Take the time to teach students to chart. See "Teaching Students to Chart," pages 34-37. Students accept the chart readily and usually learn very quickly how to use it.

WHY DO WE NEED TO USE THAT FUNNY LOOKING CHART?

The chart used for most one minute timings is the AC-4. This chart is a revision of the original Standard Behavior Chart developed by Ogden Lindsley. The Standard Behavior Chart should be used for academic or social behaviors that are counted for longer than one minute. Both charts are semi-logarithm or multiply-divide charts. These charts reflect proportional change or growth. Students learn proportionately and not in equal intervals. Therefore, the semi-logarithm charts depict learning more accurately.

The charts used in this manual are copied from the original AC-4 with the permission of the author. Teachers should use the original charts with their students and can order them from the address below:

Academic Behavior Chart
AC-4, 1rm. - \$25.00
Performance Data Co.
P.O. Box 13289
Gainesville, Florida 32604

For more information on using the Standard Behavior Chart a good source is Koorland and Martin, Elementary Principles and Procedures of the Standard Behavior Chart, Learning Environments, Inc., Gainesville, Florida, 1975.

Sept. 3, 1982

SUNDAY'S DATE

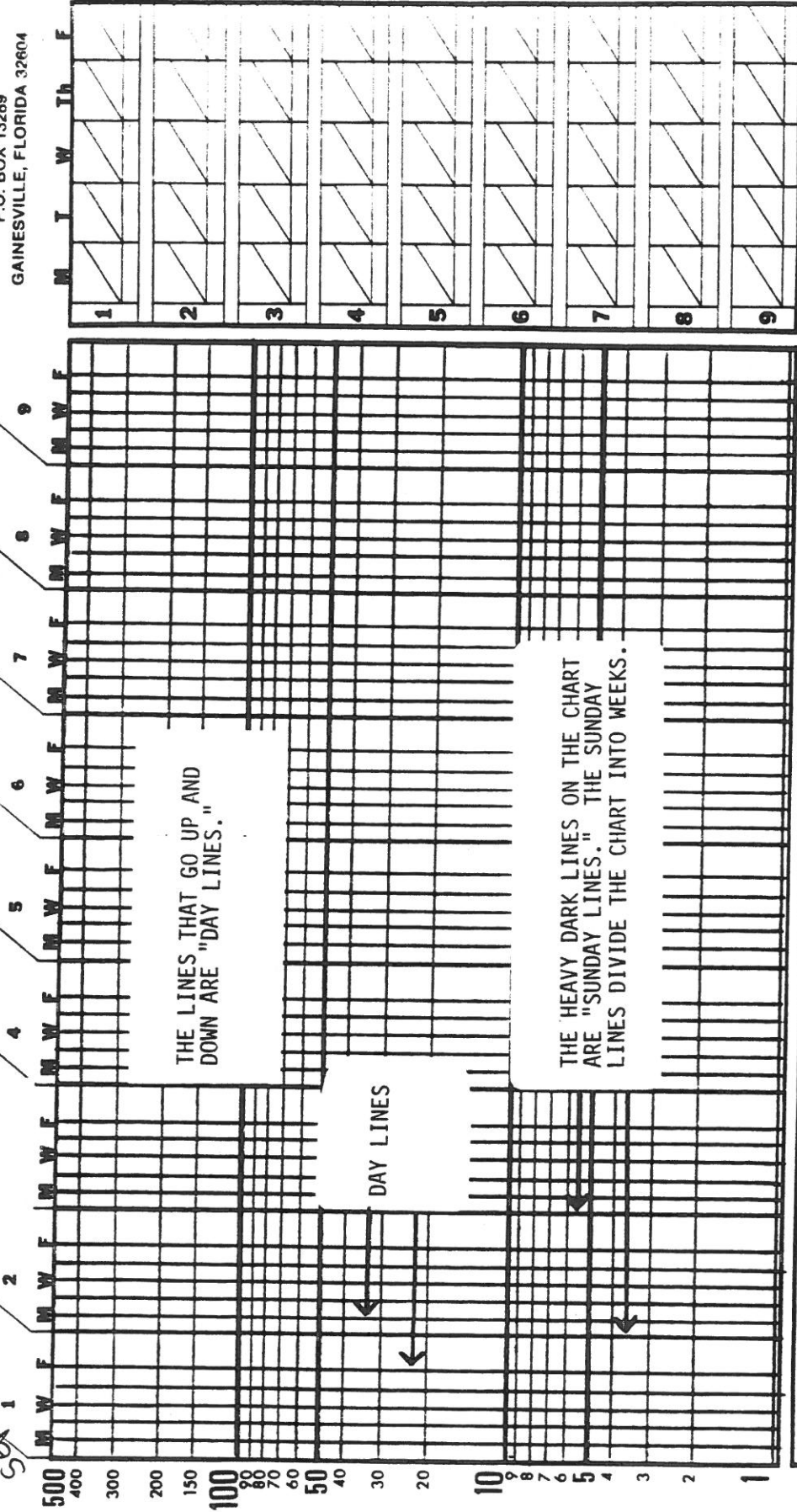

AC-4

PERFORMANCE DATA CO.
P.O. BOX 13289
GAINESVILLE, FLORIDA 32604

NAME _____

GRADE _____

BEHAVIOR _____

GOAL _____

© Amb., 1979

AC-4
 PERFORMANCE DATA CO.
 P.O. BOX 13289
 GAINESVILLE, FLORIDA 32604

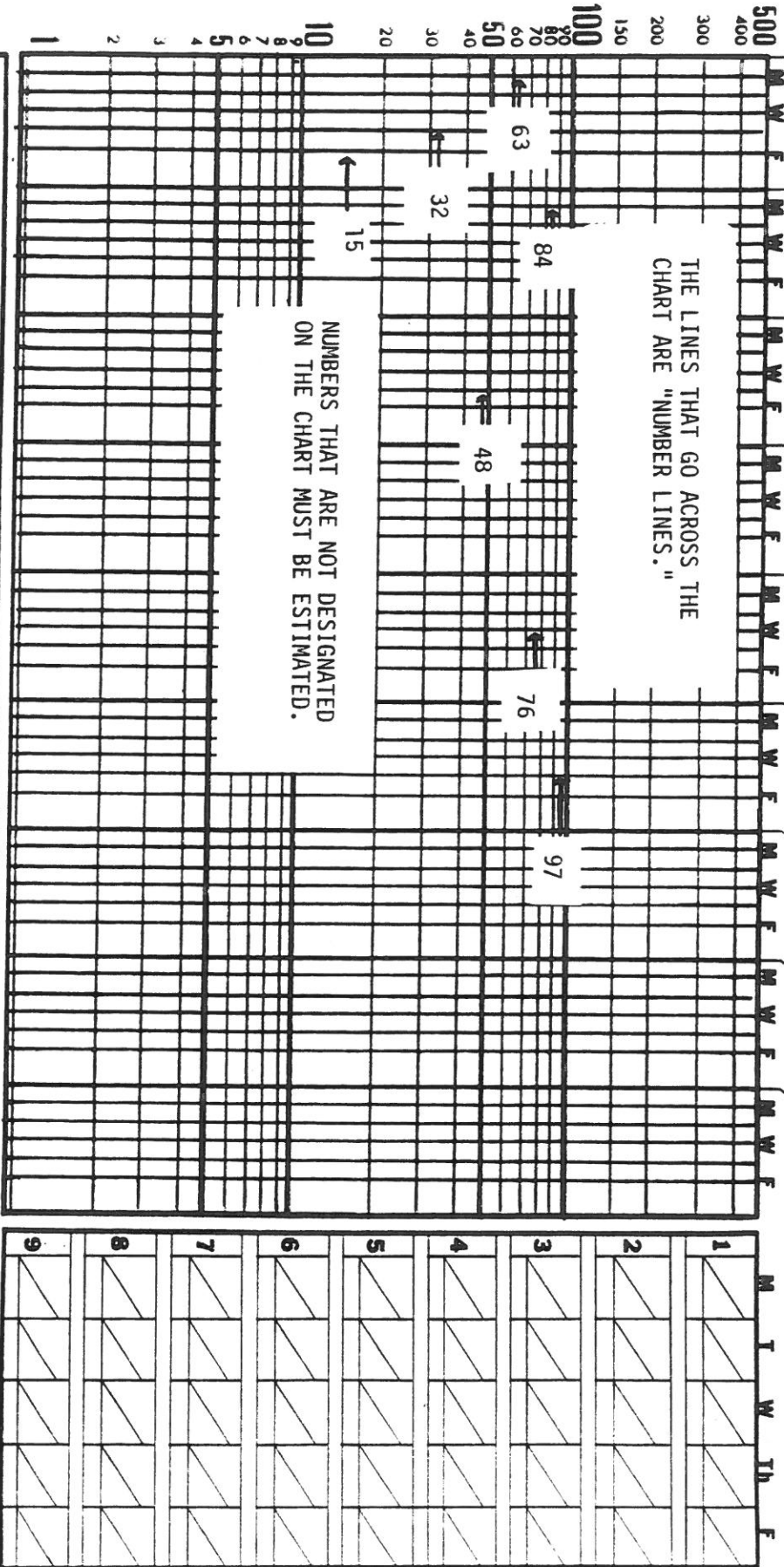

NAME _____

BEHAVIOR _____

GRADE _____

GOAL _____

	M	T	W	Th	F
1					
2					
3					
4					
5					
6					
7					
8					
9					

AC-4

PERFORMANCE DATA CO
P.O. BOX 13289
GAINESVILLE, FLORIDA 32604

Sept. 3, 1982
Sept. 10, 1982
Sept. 17, 1982
Sept. 24, 1982
Oct. 1, 1982
Oct. 8, 1982
Oct. 15, 1982

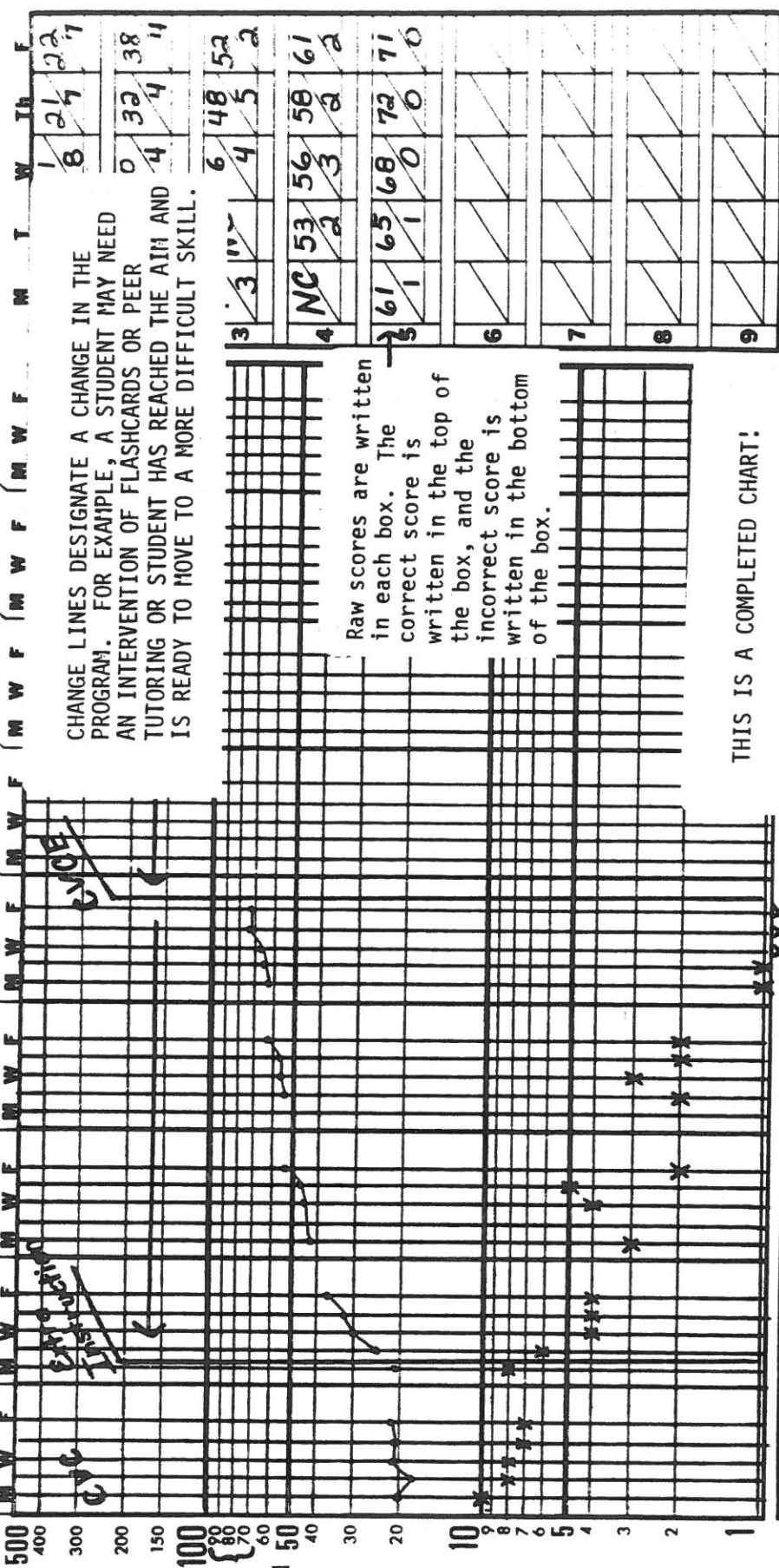

CHANGE LINES DESIGNATE A CHANGE IN THE PROGRAM. FOR EXAMPLE, A STUDENT MAY NEED AN INTERVENTION OF FLASHCARDS OR PEER TUTORING OR STUDENT HAS REACHED THE AIM AND IS READY TO MOVE TO A MORE DIFFICULT SKILL.

Raw scores are written in each box. The correct score is written in the top of the box, and the incorrect score is written in the bottom of the box.

THIS IS A COMPLETED CHART:

NAME Sally Student GRADE 3rd

BEHAVIOR See-say phonetic words GOAL 70-90

TEACHING STUDENTS TO CHART

When introducing the chart to students the following lessons will aid the teacher in giving a clear and simple description of charting procedures. Use a transparency of the chart or a chart sketched on the chalkboard as the visual aid. Repeat these lessons daily for several days to ensure that students are comfortable with the chart. When the students have become proficient at charting their daily scores, charts should be reviewed weekly in order to make effective data decisions.

Lesson 1

Look at chart

Say: *Day lines go up and down on the chart. What are the lines that go up and down? (Repeat this question several times.)*

Say: *The heavy dark lines that go up and down are Sunday lines. What are the heavy dark lines that go up and down? (Repeat.)*

Say: *The Sunday lines divide the charts into weeks. Count the weeks on the chart: 1, 2....9. How many weeks are there?*

Point to the slanted line above the Sunday line.

Say: *This is where we put the Sunday date. Sunday is the first day of the week, so we put the Sunday date for the weekly date.*

Say: *The lines that go across the chart are number lines. What do we call the lines that go across the chart? (Repeat.)*

Say: *Find the number lines for 1, 2.....10, 20, 30, 40, 50....100, 200, etc. Students can point to the number lines as teacher calls out the number. The teacher needs to monitor correct responses by walking around and checking students.*

Demonstrate several easy examples to chart raw score.

Say: *Next we write our score in the box on the right side of the chart. Point to the first row of boxes with the "1" beside it. Point to the box with an "M" above it. This is the Monday box and this is where we write our score for Monday. The correct score goes in the top of the box and the incorrect score goes in the bottom of the box. Point out each box and the day of the week that goes with it. (T, W, Th, F)*

Say: *Now we are ready to chart our score. Find the week with the "1" above it. Explain that this is Week One and it is the week we begin to chart on first. Demonstrate as you explain.*

Say: *Look at the correct score. It is 5, so we go up the number line to 5 then across to the Monday day line. We put a ● on the day line for correct. Now look at the incorrect score. It is 4 so we go up the number line to 4 then across to the Monday day line. We put an X on the day line for incorrect. Don't make the ● and the X too big or too small. Remember to put the ● and the X on the day line.*

Say: *On the day when you do not do the timing due to absence or special activity, etc. skip that day on the chart. Write NC (no chance) in the score box for that day on the side of the chart.*

Make up scores for the rest of the week (T, W, Th, F) and use the same method to demonstrate charting these scores.

Demonstrate as you explain.

Say: *You can connect the •'s to •'s and the X's to X's for one week at a time. Do not draw lines through Sunday lines.*

Give the students several easy examples to chart on the "Charting Practice Sheet." No estimating yet!

Lesson 2

Review day lines, number lines, Sunday lines, Sunday date, no chance days. Review the simple charting procedure. Introduce the concept of "estimating."

Demonstrate as you explain.

Say: *What if we have a correct score of 21? We do not have a 21 number line. We have to estimate - that is guess as accurately as possible where that number line would be. Is 21 closer to the 20 or 30 number line? It is closer to the 20 number line so we put our pencil right above the 20 number line and go to the correct day line and put a • .*

Say: *What if our score is 28? Is it closer to the 20 or 30 number line? It is closer to the 30 number line so we put our pencil right below the 30 number line and go over to the correct day line and put a • .*

Have students use the "Charting Practice Sheet" to chart examples that require estimating up to the 50 number line.

Lesson 3

Review charting vocabulary with students. Introduce estimating with examples above 50. Use teaching method in Lesson 2. Since the distance between 50 and 60 is smaller on the chart, students need practice in estimating smaller distances. Give students the "Charting Practice Sheet" to chart examples that require estimating above the 50 number line.

Introduce Phase or Change Lines

Demonstrate as you explain.

Say: *Many times we make changes in our work. We can make a change by going on to a new practice sheet when we reach our aim or we can change our work because we may not be improving for several days. Any type of change needs to be noted on the chart.*

Say: *To make a change line on the chart we take a sharp pencil and a ruler and draw a line up and down and halfway between the day lines. If we reach our aim on Tuesday we draw a line halfway between the Tuesday and Wednesday day lines.*

Say: *The change line is like a stop sign - it tells us to stop and go on to something else.*

Demonstrate how to label the change line with a short description of the change. Students may use different colors to draw change lines. Students may practice drawing change lines on the "Charting Practice Sheet." The students should now be ready to chart on the AC-4 Chart.

CHARTING PRACTICE SHEET

NAME _____

DATE _____

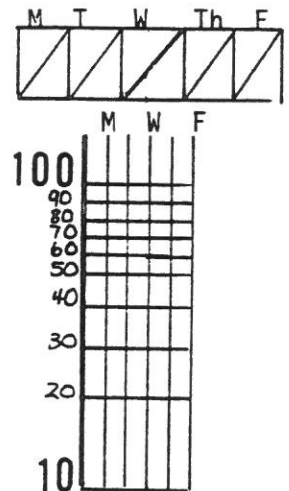
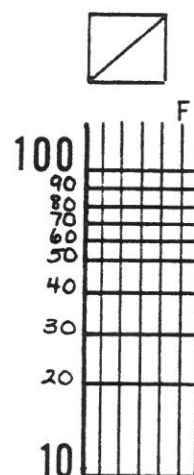
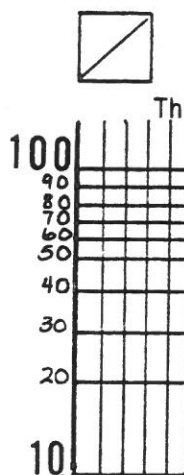
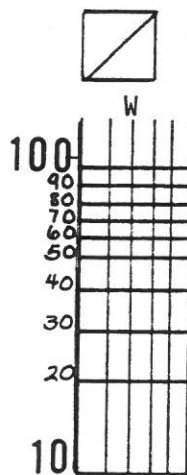
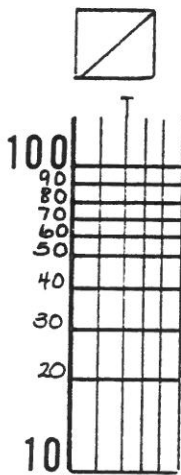
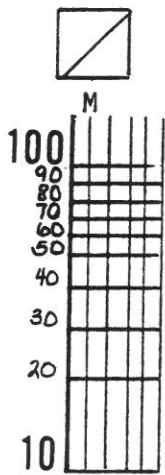
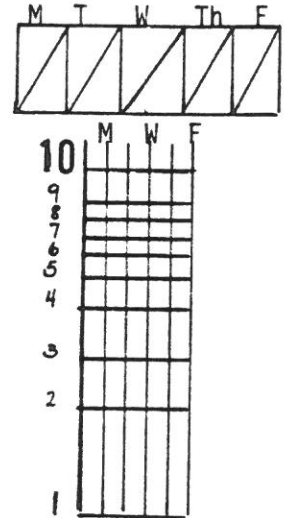
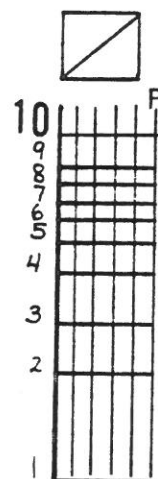
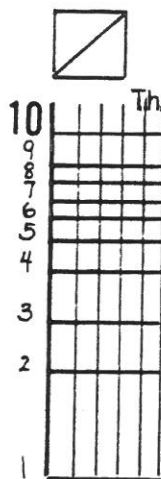
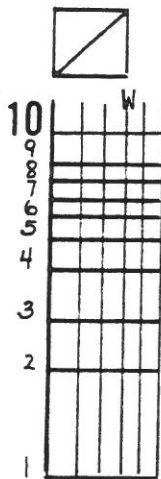
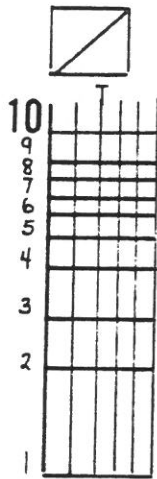
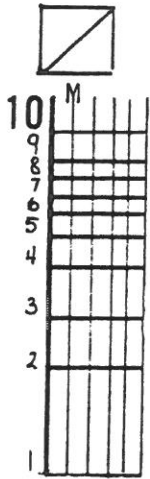



DECISION-MAKING

After charting several scores students will have a picture of their learning. Learning is a change in performance. If a student's chart shows a progressing change it can be assumed that he/she is learning. If the learning picture shows that no change or a negative change is occurring an intervention should be made.

Some examples of curriculum interventions are:

- Step - A step is a change in the skill that has been pinpointed. A step ahead can be made to a more difficult skill or a step back to a prerequisite skill. For example, if the student is working on reading CVC words and not improving, the teacher can make a step back to work on short vowel sounds or consonant sounds.

- Slice - A slice is breaking the skill into component parts. For example, if the student is working on addition facts 0-18 and having difficulty, the teacher may want to slice back to sums 0-9 or 0-5.

AC-4
 PERFORMANCE DATA CO.
 P.O. BOX 13289
 GAINESVILLE, FLORIDA 32604

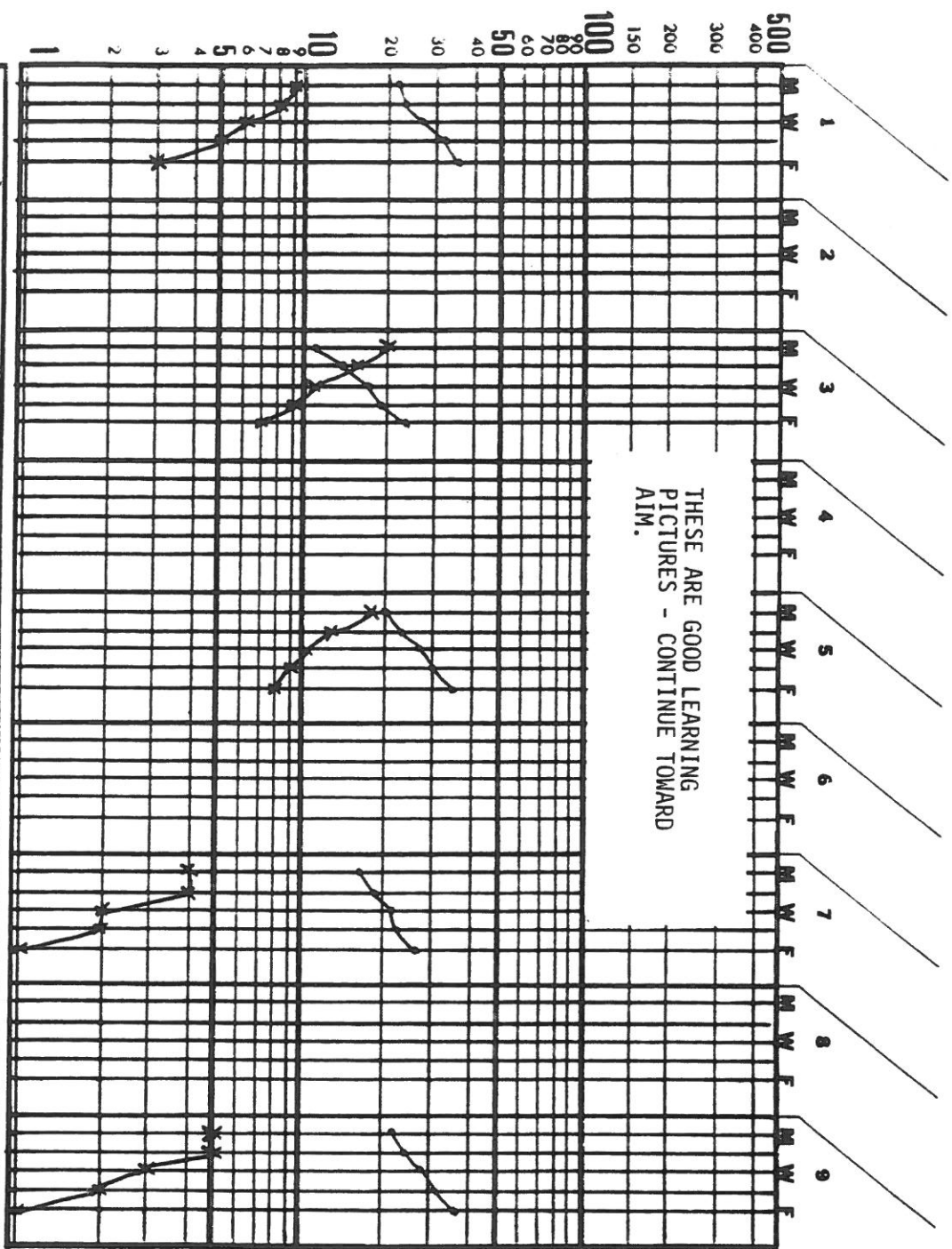

	M	T	W	Th	F
1					
2					
3					
4					
5					
6					
7					
8					
9					

NAME _____

GRADE _____

BEHAVIOR _____

GOAL _____

© gmb, 1979

AC-4

PERFORMANCE DATA CO.
P.O. BOX 13289
GAINESVILLE, FLORIDA 32604

1	M	T	W	Th	F
2	M	T	W	Th	F
3	M	T	W	Th	F
4	M	T	W	Th	F
5	M	T	W	Th	F
6	M	T	W	Th	F
7	M	T	W	Th	F
8	M	T	W	Th	F
9	M	T	W	Th	F

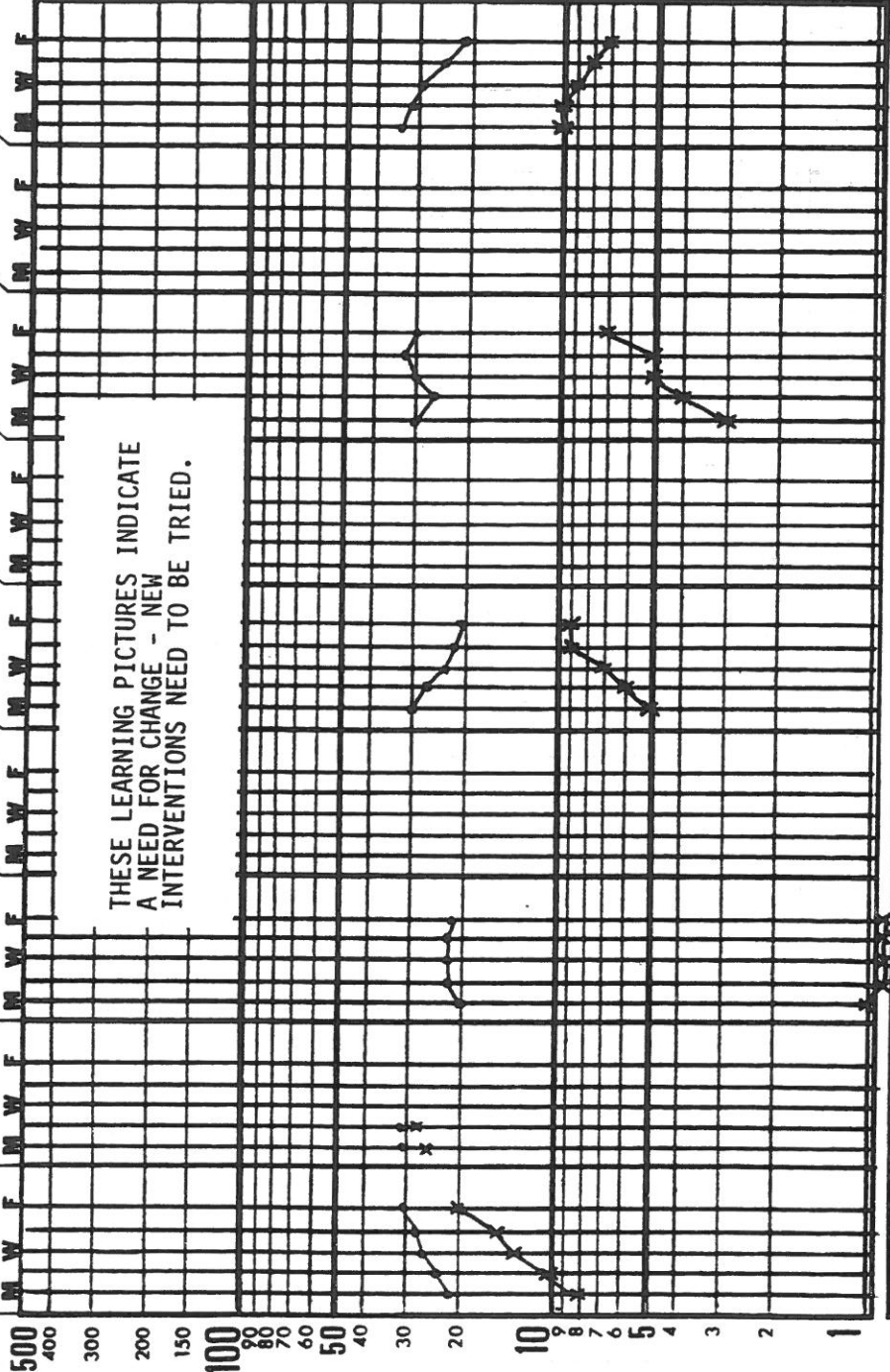

NAME _____

GRADE _____

BEHAVIOR _____

GOAL _____

© emb. 1979

To be better prepared in interpreting learning pictures it is necessary to look at the stages of skill development.

STAGES OF LEARNING

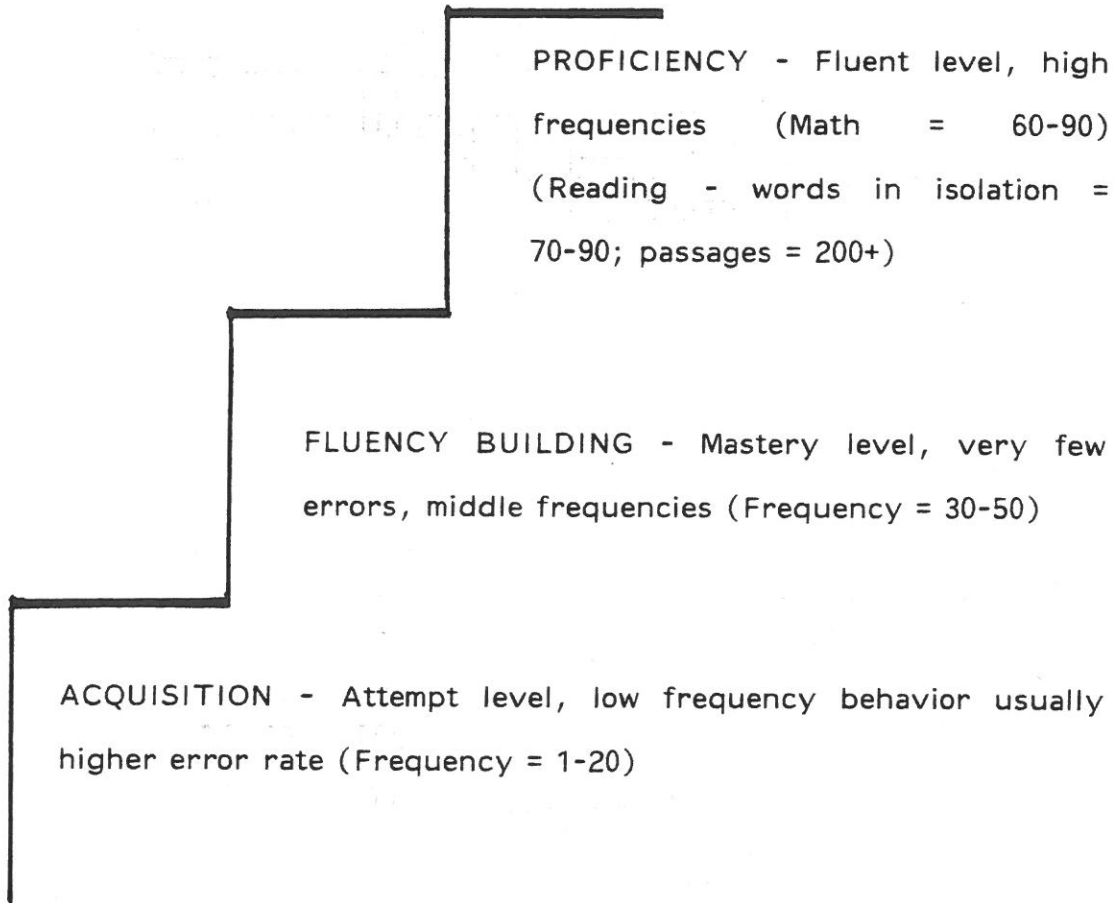

SKILL BUILDING TECHNIQUES*

There are many techniques to aid the teacher in improving student learning. It is beneficial to look at the charted data first and make decisions accordingly.

The following methods are a good guide for students who are in these learning stages:

ACQUISITION - Direct instruction is desirable. Check on tool skills - Pairing tool skill timing with basic skill timing. Check to make sure learning channel is correct for student - Make change if needed. Provide answers for task at beginning of stage. Model for student (especially effective in reading). Instruction for errors, skips, omissions. Slice back - Step back. Contingency management.

FLUENCY - Provide practice: flashcards, think-write tasks, BUILDING tape recorder, games, board work, etc. Check on tool skills. Model for student (especially effective in reading). Pacing practice - use metronome. Untimed practice. Contingency management.

PROFICIENCY - Data flattens out: move on to a more difficult STAGE (at skill. Data still growing: allow data to continue aim for 2-3 to grow, raise aim. Move on to more difficult days) skill.

*Adapted from the Precision Teaching Project Training Manual, Great Falls Public Schools, Great Falls, Montana.

To get practice in basic decision-making read each example below and chart the data on the following page. After reviewing the data make decisions about each student's learning. Check your answers with the key on page 59.

Counting Behavior: See-write add facts (0-9) - Goal = 60-80

	<u>Correct</u>	<u>Incorrect</u>		<u>Correct</u>	<u>Incorrect</u>
Monday	33	7	Monday	56	3
Tuesday	42	6	Tuesday	57	2
Wednesday	48	4	Wednesday	56	2
Friday	53	3	Thursday	55	1

Counting Behavior: See-say Dolch words - Goal = 70-90

	<u>Correct</u>	<u>Incorrect</u>		<u>Correct</u>	<u>Incorrect</u>
Monday	12	6	Monday	15	5
Tuesday	15	6	Tuesday	13	4
Thursday	13	5	Wednesday	14	5
Friday	14	4			

Counting Behavior: See-say CVC words - Goal = 60-80

	<u>Correct</u>	<u>Incorrect</u>		<u>Correct</u>	<u>Incorrect</u>
Monday	42	7	Monday	63	2
Tuesday	48	4	Tuesday	66	1
Wednesday	55	5	Wednesday	72	0
Thursday	59	3	Thursday	76	0

AC-4

PERFORMANCE DATA CO.
P.O. BOX 13289
GAINESVILLE, FLORIDA 32604

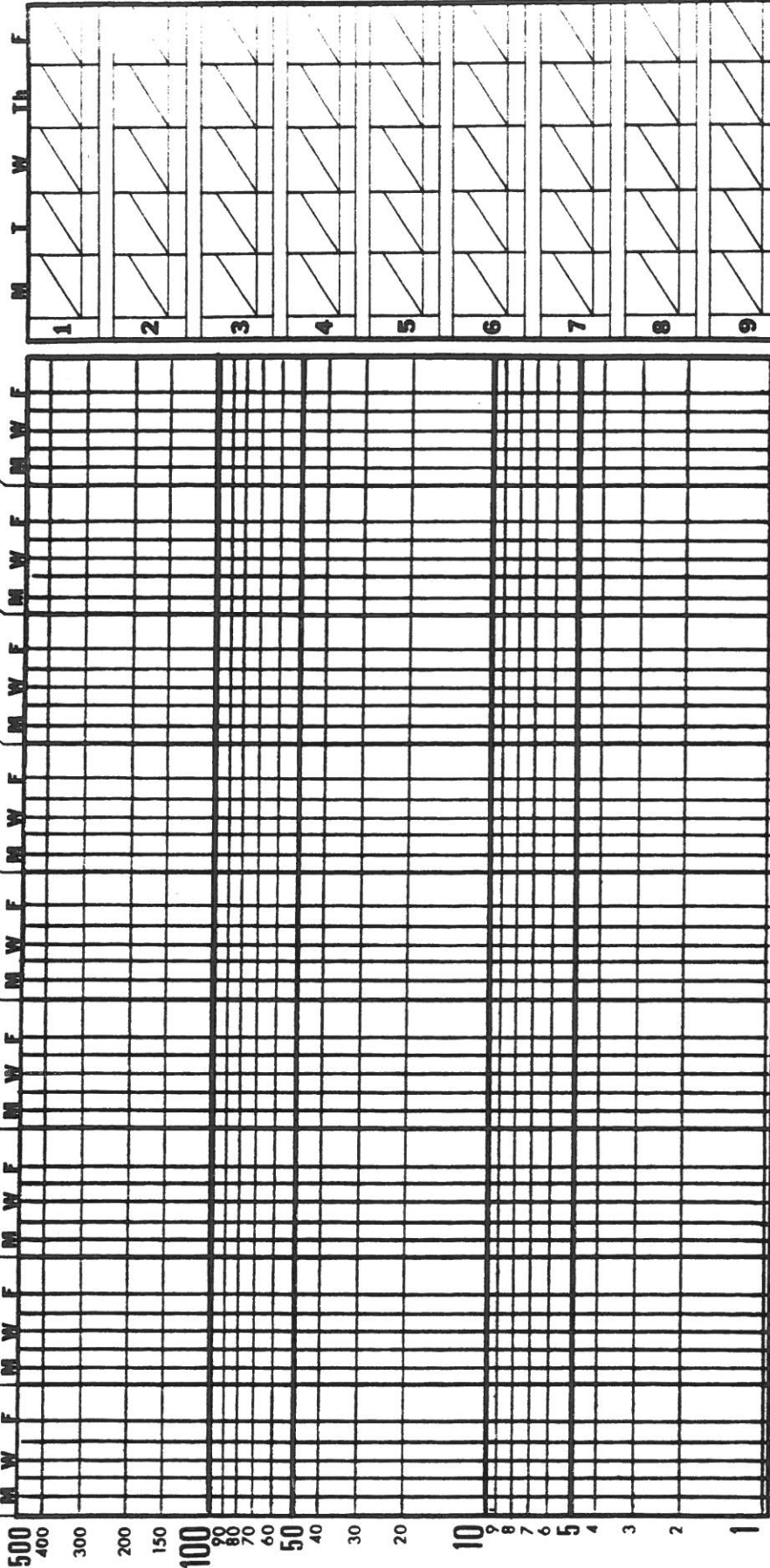

NAME _____ GRADE _____
BEHAVIOR _____ GOAL _____

© emb. 1979

CELERATION

Celeration is a method of measurement that can be used to determine the trend in the student's learning. This behavior change can be computed by comparing the frequency of one day to a frequency exactly seven days later. If the end of the week frequency is greater than the beginning of the week frequency the behavior is increasing and it is a (X) celeration. If the end of the week frequency is smaller than the beginning of the week frequency the behavior is decreasing and it is a divide (\div) by celeration.

Acceleration - X Celeration

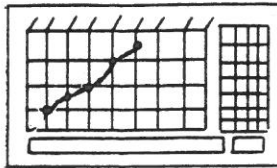

Deceleration - \div Celeration

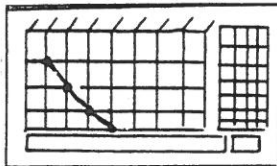

Lines are drawn through the responses (\bullet 's or x's) on the chart to reflect visually the slope and direction of the change. These lines can be drawn for a period longer than one week. There are several methods for drawing celeration lines. The "Freehand Method" is just a matter of drawing a line that will split the responses (\bullet 's or x's) in half so there are an equal number of \bullet 's or x's above and below the line.

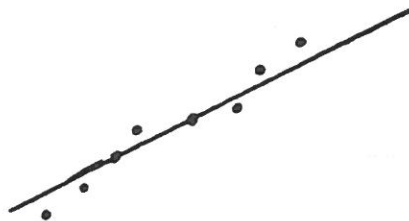

The "Split Middle" Technique is more complicated and needs detailed instruction. Read the following outline and use the illustrations on pages 48-49 to learn this technique.

The "Quickie" or "Split-Middle" Technique for Estimating
the Celeration Line*

1. Divide the data into two equal parts. These parts will be called the "first-half" and "second-half." The same number of dots should be on each half. (If there are an even number of data points, place the vertical line between two halves. If there are an odd number of data points, place the vertical line on a data point making both sides even.)
2. Find the middle day for the "first-half" and "second-half." Draw a vertical line through these "mid-days." (If there are an even number of data points, place the vertical line between two halves. If there are an odd number of data points, place the vertical line on a data point making both sides even.)
3. Find the middle rates for the first and second halves (i.e., rank scores on both halves and find the median score for each half). Draw a horizontal line through each mid-rate in the "first-half" and "second-half."
4. Draw a line from the intersection of the mid-day and mid-rate of the "first-half" to the intersection of the mid-day and mid-rate of the "second-half."
5. Count the number of data points falling above and below the line. If there are the same number above or below then you are finished. You may have to adjust the line (by moving it up or down) until there are the same amount of dots above and below.

NOTE: It is not always possible to get a perfect split because more than one data point may fall on the celeration line. Just try and get as even a split as possible.

*Adapted from White and Haring, Exceptional Teaching, Charles Merrill Publishing Company.

AC-4
 PERFORMANCE DATA CO.
 P.O. BOX 13289
 GAINESVILLE, FLORIDA 32604

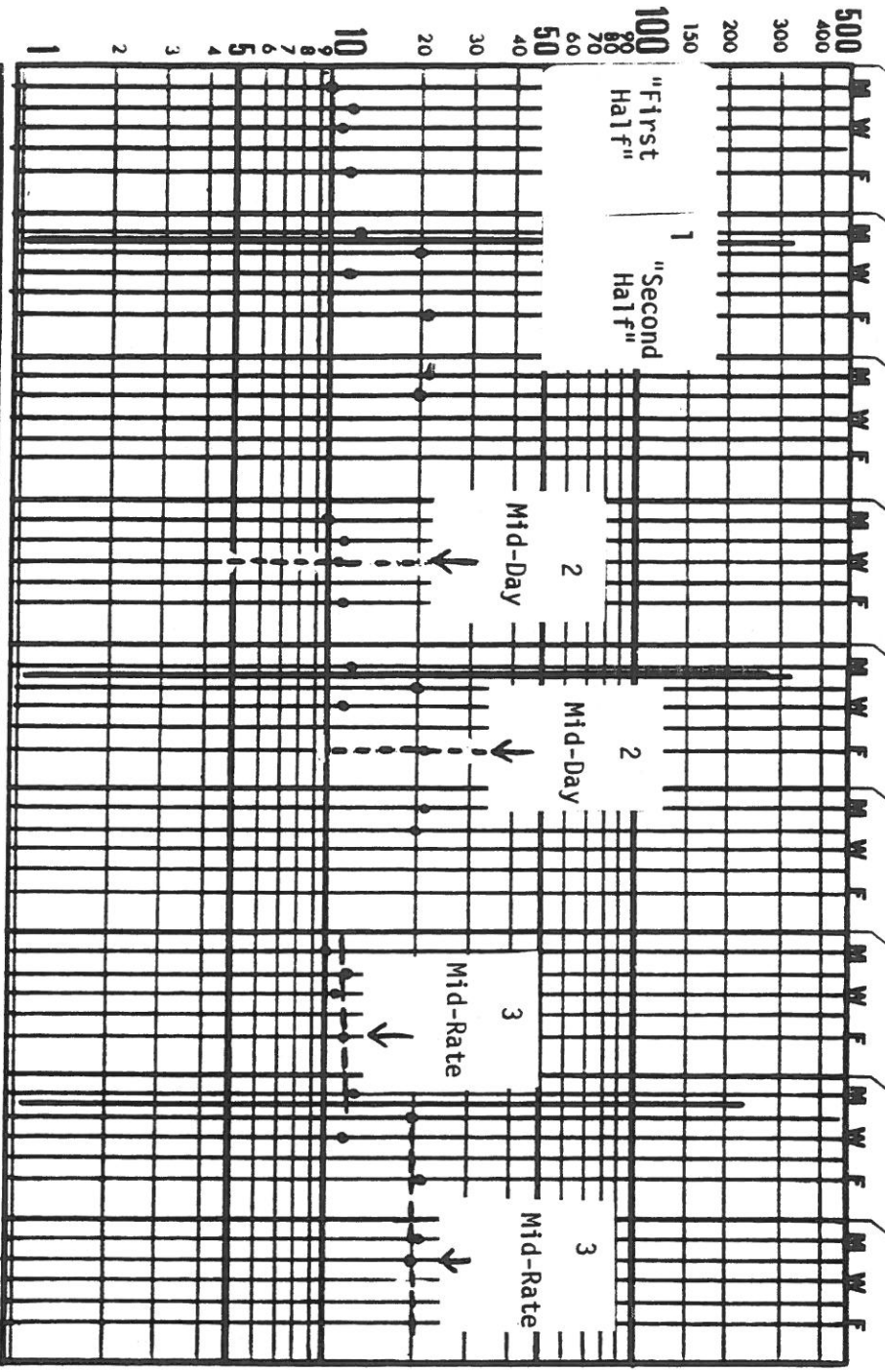

	M	T	W	Th	F
1	/	/	/	/	/
2	/	/	/	/	/
3	/	/	/	/	/
4	/	/	/	/	/
5	/	/	/	/	/
6	/	/	/	/	/
7	/	/	/	/	/
8	/	/	/	/	/
9	/	/	/	/	/

NAME _____

GRADE _____

BEHAVIOR _____

GOAL _____

AC-4

PERFORMANCE DATA CO.
P.O. BOX 13289
GAINESVILLE, FLORIDA 32604

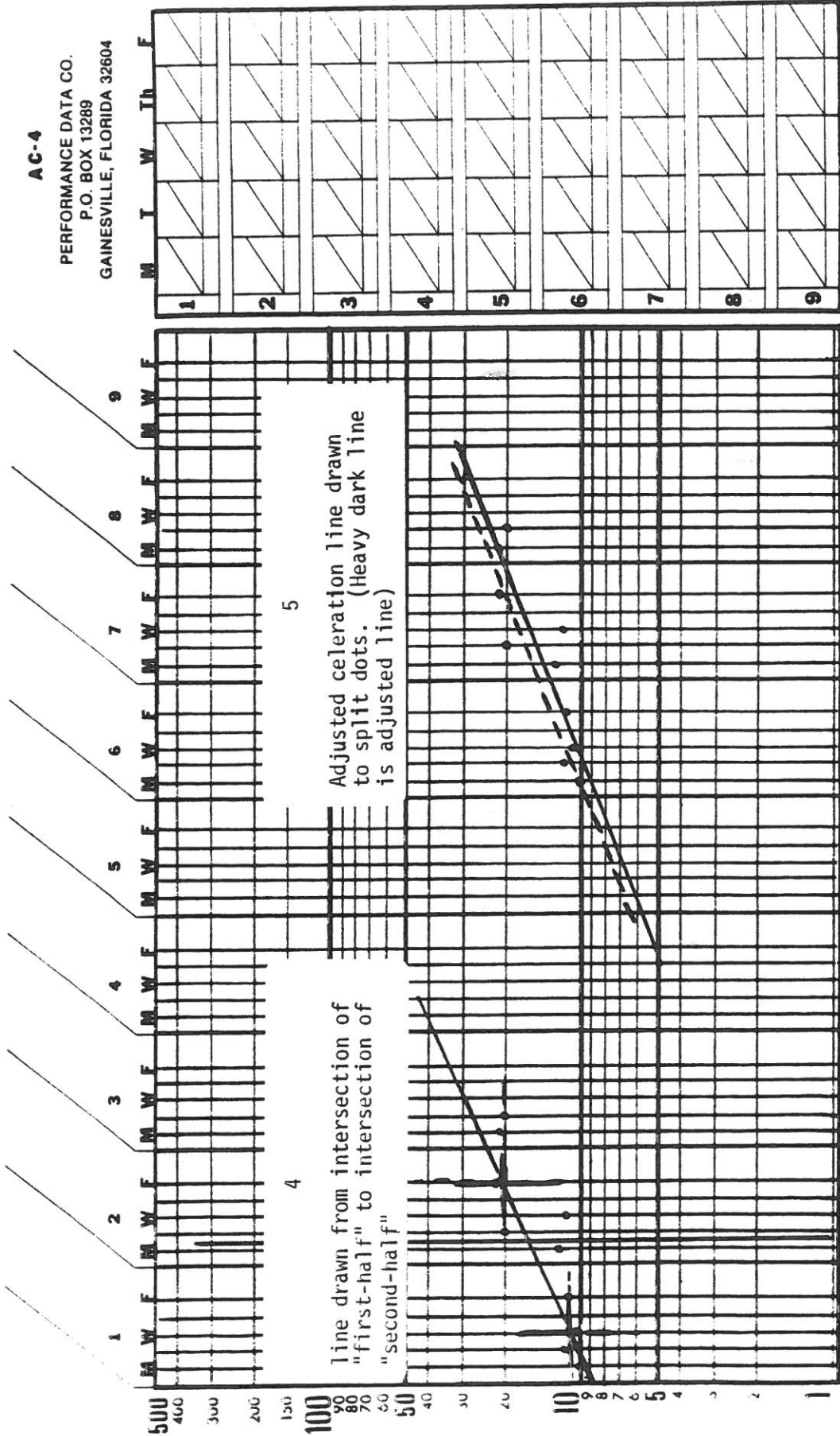

NAME _____

GRADE _____

BEHAVIOR _____

GOAL _____

NAME _____

GRADE _____

BEHAVIOR _____

GOAL _____

After celeration lines have been drawn the value of the line needs to be designated. Since the scale of the chart is an equal ratio chart the celeration values will be expressed as ratios such as $\times 1.8$ or $\times 2$ for acceleration. $\div 2$ or $\div 3$ are ratios for deceleration. If there is no change in the behavior the celeration is described as $\times 1.0$

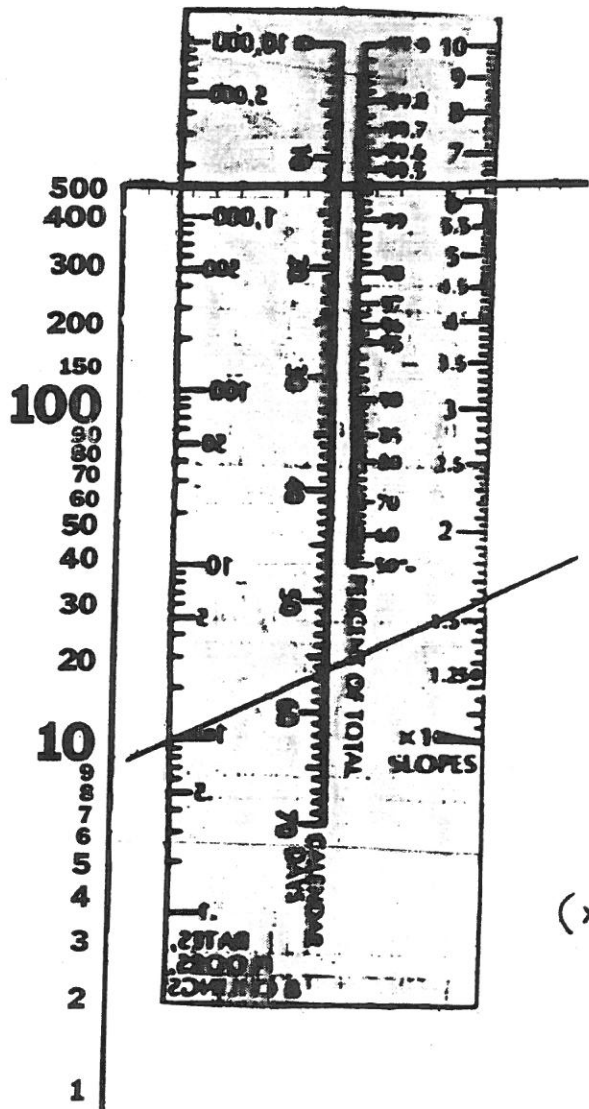

Using the Celeration Finder

- A. Draw the learning line.
- B. To determine celeration
 1. Place the finder on the chart so that the scale labeled "slopes" is on the right-hand side of the finder.
 2. Line up the finder so it is straight up and down on the chart and on top of the line to be measured.
 3. Move the finder up or down (making sure it stays perfectly vertical on the chart) until the arrow on the left-hand side of the finder touches the line to be measured.
 4. Read the slope of the line by noting the point at which the line crosses the slopes scale of the finder.

Adapted from White and Haring, Exceptional Teaching, Charles Merrill Publishing Company.

Celeration finders can be made by making a transparency of this page and cutting out the individual finders.

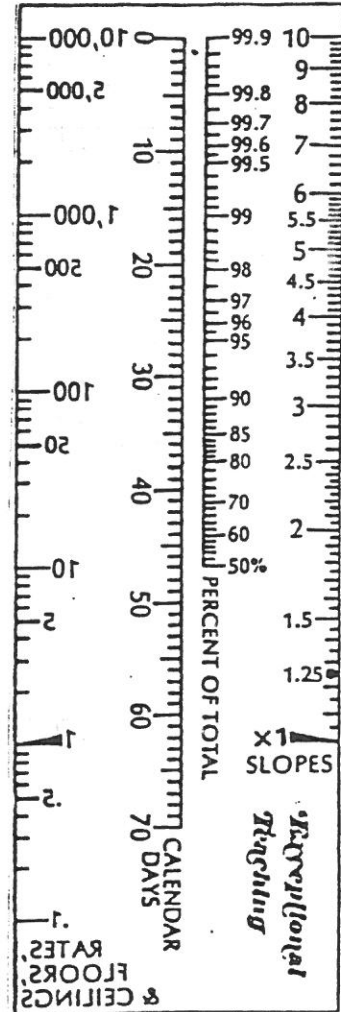
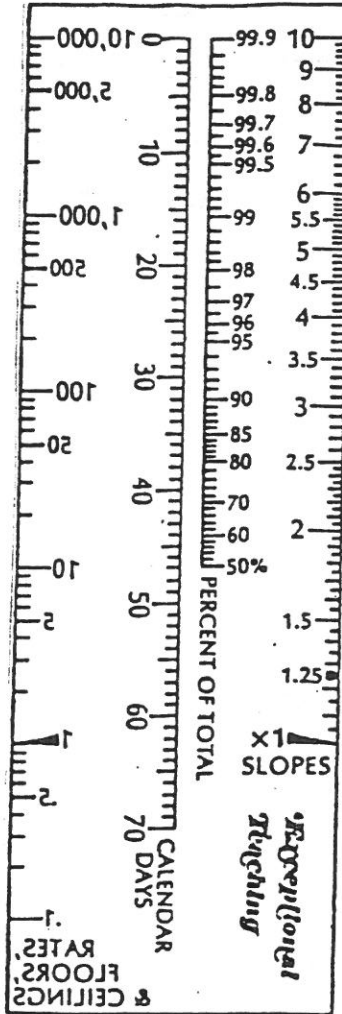
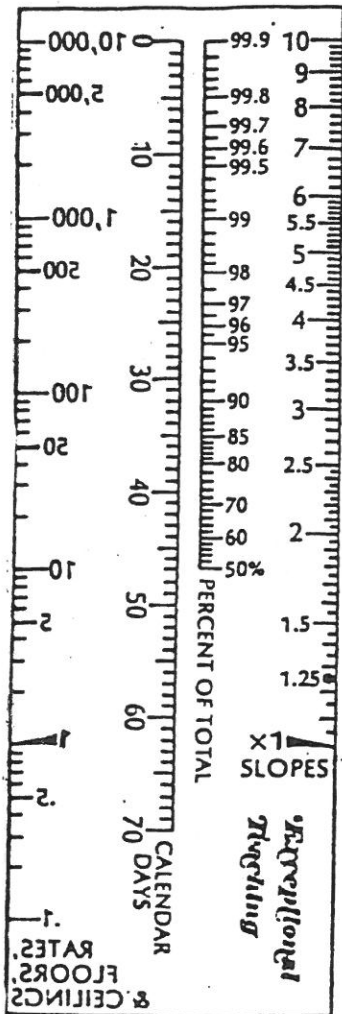

If there is no frequency finder available the teacher can determine the value of the celeration line by using the raw data. Using two weeks of data:

A. Find median frequencies for each week (the middle score when scores are ranked ordered from smallest to largest).

1. If there are an odd number of scores, use the middle score.

Example: 3 7 12 10 11 Median = 10

2. If there are an even number of scores, find the median by using the average of the two middle scores.

Example: 3 7 11 9 Median = 8

B. Divide the smaller median into the larger median (carry out three decimal places and round-off to two).

C. Indicate with an (X) or (\div).

1. If a smaller number occurs during the first week, indicate this with a (X) celeration.

2. If a smaller number occurs during the second week, indicate this with a (\div) celeration.

Example: Step 1: Week One Median = 10

Week Two Median = 15

Step 2: $10 \overline{)15.} = 1.50$

Step 3: X 1.50

*Adapted from the Precision Teaching Project Training Manual, Great Falls Public Schools, Great Falls, Montana.

AC-4

PERFORMANCE DATA CO.
P.O. BOX 13289
GAINESVILLE, FLORIDA 32604

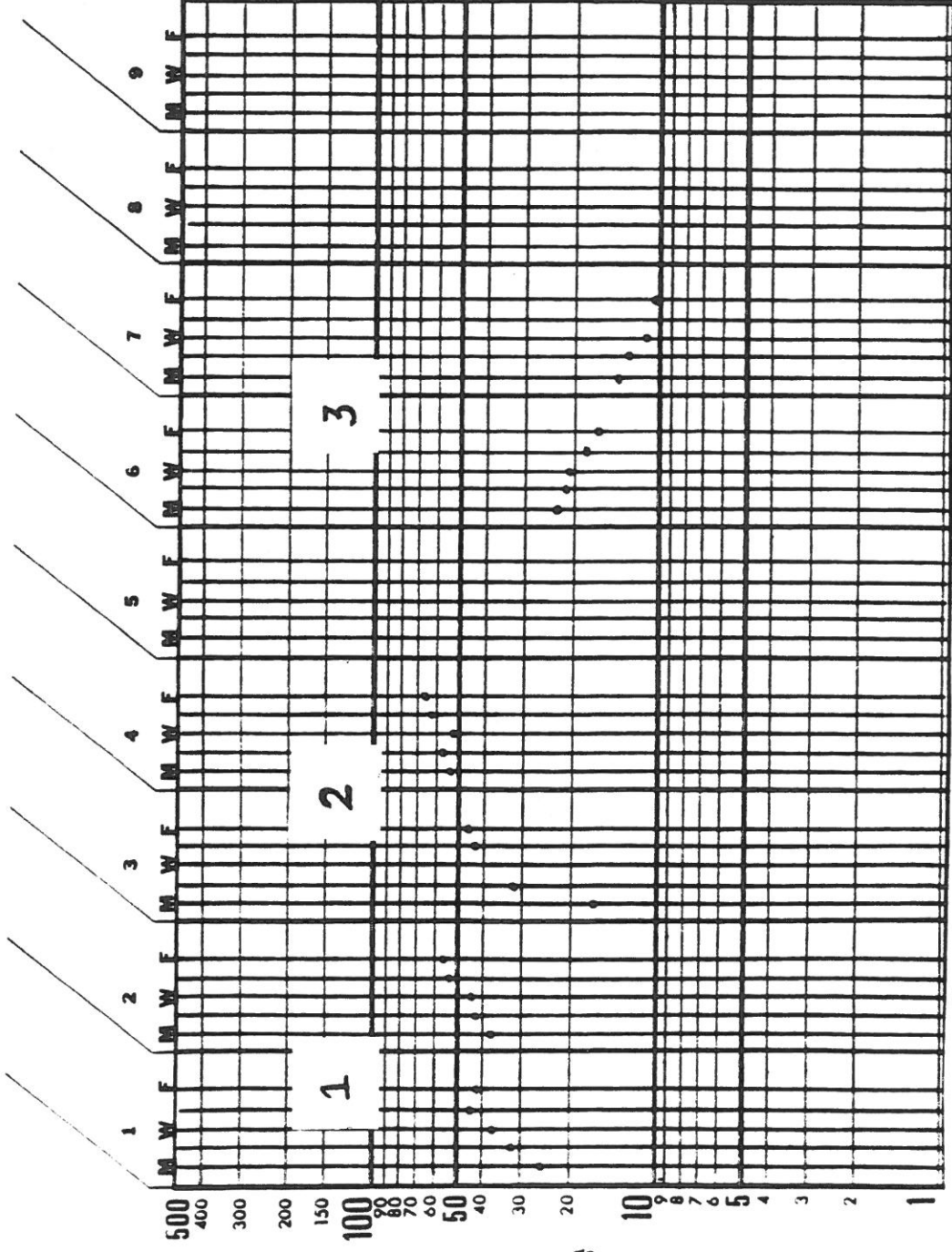

Use the "Split Middle" Technique to draw the celeration lines for the data on the chart above. Use the celeration finder to find the value of the lines. Check your answers with the key on the following page.

AC-4
 PERFORMANCE DATA CO.
 P.O. BOX 13289
 GAINESVILLE, FLORIDA 32604

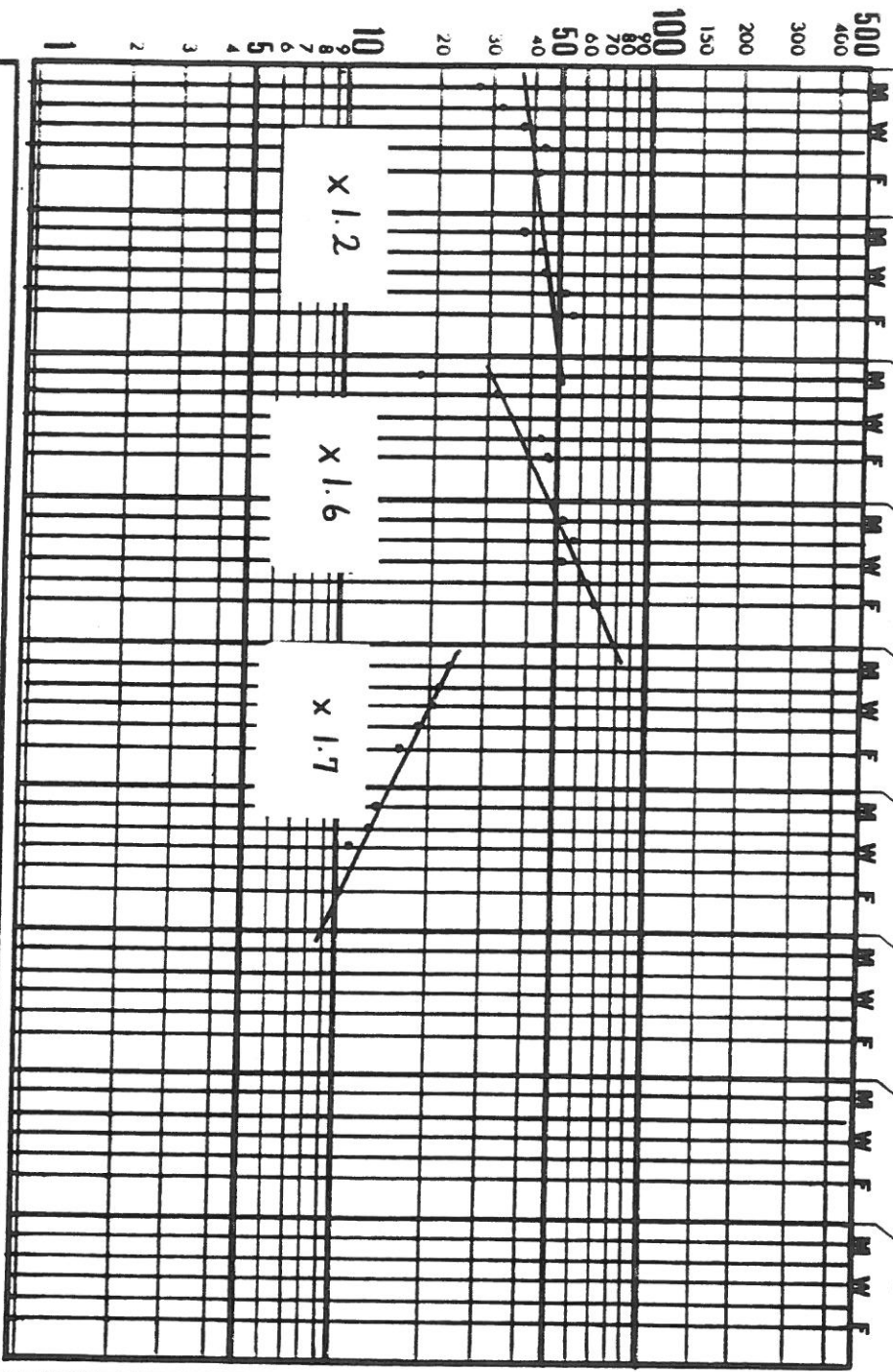

	M	T	W	Th	F
1	/	/	/	/	/
2	/	/	/	/	/
3	/	/	/	/	/
4	/	/	/	/	/
5	/	/	/	/	/
6	/	/	/	/	/
7	/	/	/	/	/
8	/	/	/	/	/
9	/	/	/	/	/

NAME _____

GRADE _____

BEHAVIOR _____

GOAL _____

STEPS FOR EFFECTIVE DECISION-MAKING*

1. Set individual aims for students
 - a. long range aims, i.e., 70-90 correct with 2 errors or less.
 - b. weekly aims - set the aim you want student to reach by end of week.
 - c. daily aims - set the next day's score slightly higher than previous day's score.

2. Review charted data before making decisions. The following items will be helpful in deciding when you need to make decisions.
 - a. aim met for 2 out of 3 days
 - b. three days of flat data
 - c. less than minimum progress (X1.25)
 - d. corrects decreasing

3. Make appropriate interventions.

4. Try, try again.

*Adapted from the Precision Teaching Project Training Manual, Great Falls Public Schools, Great Falls, Montana

Read the following examples and chart the data on page
 After reviewing the data make appropriate decisions for each student.
 Check your answers with the key on page 59.

Chris is an eight-year-old third grader. She does daily one minute see/write timings on basic multiplication facts, sums 0-18. Her aim is to reach 70-80 correct digits with two or fewer errors. She can write 130 numbers (0-9) in one minute.

<u>Day</u>	<u>Date</u>	<u>Correct</u>	<u>Incorrect</u>
M	9-14	12	3
T	9-15	14	4
W	9-16	13	3
Th	9-17	12	3
F	9-18	11	4

Jay is a fourth grader. He does daily one-minute timings on see/say vocabulary words. His aim is to reach 70-90 correct words with two or fewer errors.

<u>Day</u>	<u>Date</u>	<u>Correct</u>	<u>Incorrect</u>
M	10-2	50	2
T	10-3	51	2
W	10-4	53	0
Th		Absent	
F	10-6	54	0
M	10-7	54	0
T	10-8	54	0

Betty is a second grader and is on see/write addition facts 0-9. Her goal is 60-80 correct digits in one minute with two or less errors. Math is a difficult subject area for her. She can write 60 numbers (0-9 serial) in one minute.

<u>Day</u>	<u>Date</u>	<u>Correct</u>	<u>Incorrect</u>
M	11-4	30	4
T	11-5	32	3
W	11-6	Absent	
Th	11-7	31	3
F	11-8	30	4

For the following example, chart the data and draw the celeration line. Decide if the student is making minimum progress. Make appropriate decisions for this student:

David is a fourth grader and is on a see/say CVCE sheet. His goal is 70-80 correct words in one minute with two or less errors. He is a very slow reader and has very poor decoding skills. His celeration on the last skill was X1.20.

<u>Day</u>	<u>Date</u>	<u>Correct</u>	<u>Incorrect</u>
M	12-2	28	6
T	12-3	29	5
W	12-4	30	5
Th	12-5	31	4
F	12-6	32	4
M	12-9	34	3
T	12-10	36	2
W	12-11	37	2
F	12-12	39	1

AC-4

PERFORMANCE DATA CO.
P.O. BOX 13289
GAINESVILLE, FLORIDA 32604

	1			2			3			4			5			6			7			8			9		
	M	W	F	M	W	F	M	W	F	M	W	F	M	W	F	M	W	F	M	W	F	M	W	F			
500																											
400																											
300																											
200																											
150																											
100																											
90																											
80																											
70																											
60																											
50																											
40																											
30																											
20																											
10																											
9																											
8																											
7																											
6																											
5																											
4																											
3																											
2																											
1																											

NAME _____ GRADE _____

BEHAVIOR _____ GOAL _____

	M	T	W	Th	F
1	/	/	/	/	/
2	/	/	/	/	/
3	/	/	/	/	/
4	/	/	/	/	/
5	/	/	/	/	/
6	/	/	/	/	/
7	/	/	/	/	/
8	/	/	/	/	/
9	/	/	/	/	/

ANSWER KEYS

Key for page 44.

1. Fluency Building Stage. Is Tool skill (writing numbers) proficient? Extra practice - flash cards, etc. extra reinforcement, step ahead to new skill if all else fails.
2. Acquisition stage - Slice back to easier words.
More direct instruction with words - language master, tape recorder, etc.
3. Proficient - Met Aim. Can continue to grow for a few days or move on to new skill.

Key for pages 56-57.

1. Chris is in the Acquisition stage. Tool skills are great. More direct instruction with extra reinforcement may be needed. Provide answers or slice back to 0-9 as a last resort.
2. Fluency Building stage. Points or reinforcement to improve motivation. Extra practice with peer, etc. Set daily or weekly aim. If Jay gets closer but still not to aim then possibly step ahead to next level.
3. Tool skill problem. Daily timings on tool skills until gains are met. Provide fun practices on writing numbers. Positive reinforcement. Continue with 0-9 and set aim within range (40) for Betty. Raise aim as tool skill increases. Set weekly or daily aims.
4. David is making minimum celeration but since he is a fourth grader greater progress should be made. Suggested interventions might include positive reinforcement, extra practice with CVCE words and peer tutors.

CLASSROOM MANAGEMENT

Students need to be involved in managing their own learning. The teacher should encourage students to manage themselves so that no instructional time is wasted. Organize directions well. Students need to know exactly what is expected of them. Some of the following suggestions should be helpful in organizing Precision Teaching in the classroom.

MATERIALS ORGANIZATION

1. A thermal master can be made of the practice sheets that are to be used. Copies can be made and filed. The original practice sheets may be put in acetate covers to protect them for continued use.
2. Use a cardboard box with dividers to organize your practice sheets. Sub-divide the sheets by subjects such as Math: Add/Subtract/Multiply/Divide - Reading: Dolch Words Pre-Primer/Primer/1st Grade/2nd Grade.
3. Color code the materials by writing the number, title and a brief description of the practice sheets with colored marker on folder tab, i.e., (in red) A-1, Sum 0-3.

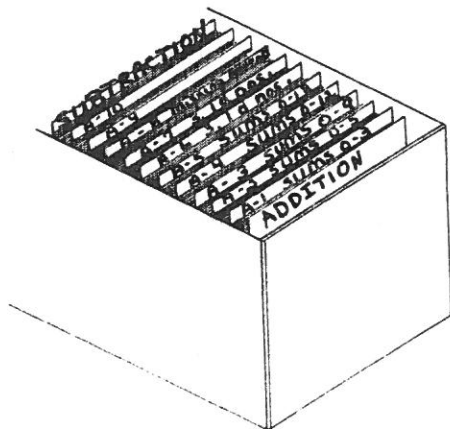

4. Teach all students to find materials. Give them a sequence of the practice sheets inside the folder and check off with a colored marker the practice sheets they are to use. This can be a guide for them to find the practice sheets in the color coded folders.

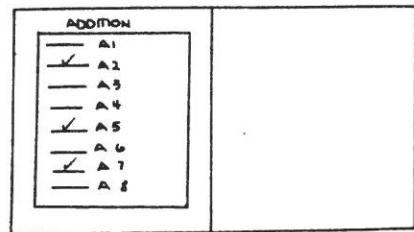

5. Designate a place for students' folders. The contents of a student's folder may include: practice sheet, acetate, answer sheet, chart and instructional materials.
6. Acetate sheets, water soluble pens (vis-a-vis) or erasable pencils (grease pencils) save on paper. You will need materials for cleaning the acetates, such as small sponges for use with the water soluble pens and "Handi-Wipes" for the grease pencils.
7. If water soluble pens are used each student can have a baggie with a small sponge inside. Vinegar water helps to sweeten the smell of sponges after continued use.
8. The acetate sheets will need to be cleaned regularly if you use grease pencils. Any spray cleaner such as 409 or fingernail polish remover is helpful in keeping them clean.

TIMINGS

1. If possible set aside the same time period each day for timings. They are effective after breaks or as the first activity of a class period. Timings seem to settle the class down quickly.

2. Establish partners to work with each other on timings. Pair students of equal ability, pair students with compatible personalities or pair younger students with older students.
3. Several devices which can be used to time are:
 - a. watch or clock with sweep hand
 - b. stop watch
 - c. timed tape and tape recorder - tape with one minute intervals of music with signals to start and stop. With a bell as the signal the following format can be set up for the tape.

*"Bell signal to start: 🔔 -Music for one minute-
 🔔 "Bell signal to stop." (15 second interval of silence)
 "Bell signal to start: 🔔 -Music for one minute-
 🔔 "Bell signal to stop." (15 second interval of silence)
 Etc.*

Continue with this same format to make a total of 5-10 minutes of one minute timings. One minute intervals of silence can be taped instead of music.

- d. A "timer person" may be established to start and stop tape or watch the clock or stopwatch.
4. Have a procedure to follow at the timing (practice, do timing, chart). Have the students practice the procedure with you so they understand what to do.

CHECKING

1. For reading, check correct and incorrect words read, for math, check correct and incorrect digits, for spelling, check correct letters in order, incorrect letters and omissions.
2. To accentuate the positive you can have the student circle all of the correct answers rather than marking the errors.

3. All students may keep an answer key in their folders. Students may complete their first practice sheet with the correct answers and that can be used as their answer sheet.
4. After students go on to a new practice sheet their answer keys can be filed for use by other students.
5. Answer keys can be mounted on heavy paper or covered with clear contact paper and filed in the back of the practice sheet folders.
6. Some teachers may prefer to have a separate answer key box with all keys filed by number.
7. As an option for reading timings assign partners. Each student will be a reader and a checker.
8. If student checkers are used, the importance of good checking should be stressed. A good rule of thumb is "the checker is always right."
9. If students are checkers for see-say timings and they are unsure of any words read they can put a "•" above the word and ask the teacher about it after the timing.

CHARTING

1. Teach all students to use the chart. Go over the chart each day as drill until they are proficient at charting. See Teaching Students to Chart.
2. Always use pencils on charts.
3. Praise or reward for clear, accurate charts.
4. Always record raw data.
5. Set up a chart checking time daily or weekly, either after the timing or during independent work time.
6. Establish charting monitors.

7. Use colored markers to connect dots and X's. This will enable the student to see vivid learning lines.

DECISION-MAKING

1. Doing timings alone will not improve skills. Timings are only to measure what has been taught. Teaching and practice must be provided.
2. Always include the student in the decision-making process.
3. Ask the student what he/she thinks is the problem.
4. Discuss aims with the student. Set daily or weekly aims to meet individual needs.
5. Errors are "good" learning opportunities, not "bad." Teach students to use them to plan instruction. "I missed all of the X's 4 so I must work on those."
6. Encourage students to skip unknowns during the timings. If they pause over unknowns they will lose their rate in the beginning. Give extra instruction with unknowns and errors.
7. Do not ask a student to practice a skill if he/she is at the attempt level. This student needs more instruction.
8. Teach students basic data decision rules.
 - a. Show examples of good learning pictures as on page 40.
 - b. Show examples of learning pictures needing help as on page 41.
 - c. Emphasize that if corrects are going up and incorrects are going down there is learning.
 - d. Stress that if there are three days of flat data a change needs to be made.

- e. Students can place a pencil over 9 to 11 days of data. Data should fall under the pencil and indicate the slope of the learning line.
9. Check for performance tensions: fidgety, anxious, squirmy. The following should help a student who is having problems:
 - a. Use calm voice.
 - b. Remind the student to relax.
 - c. Gently reassure the student during the sample.
 - d. Have the student practice breathing smoothly if the task is oral.
 - e. Have the student practice lifting the pencil if the activity is written.
 10. Offer a vacation from the timing for a few days (student may pick the days).
 11. High to low variability on the chart often indicates a compliance problem. This may be indicative of emotional or behavioral problems and should be investigated further by the teacher.

MOTIVATION

1. Emphasize to students that there is no competition with each other. Students need to "beat" their own score from the day before.
2. Take the timing before you ask children to do it or take timings with the student.
3. Set up a reinforcement bulletin board where stars are given to students for improvement or reaching their goal.

4. Help students learn how to learn - ask them what you can do to help them learn. Try to have the students discover "how they learn best."
5. To correct possible problems in cheating the following suggestions should be helpful:
 - a. Occasionally have student change papers with peers to correct.
 - b. Have all students do timing for teacher before a change is made to move on to the next skill.
 - c. Don't give the student a reason to cheat. Emphasize that charts are not graded.

GETTING STARTED

Day 1

1. Be sure to have materials well organized before you begin. See Materials Organization page 60.
2. Give the Basic Introduction to Students - see page 60.
3. Explain timing procedures to students - how to do tool skill timing, how to do regular timing - start and stop signals, work from left to right, skip unknowns and mark stop line.
4. Give timings.
5. Explain checking procedures. See pages 18-21. See pages 62-63.
6. Establish procedure for distributing materials. Assign student monitors to pass out folders or have students pick up folders upon entering room.

Day 2

1. Checking: students can now use answer keys for see-write timings to check their own papers. The teacher can monitor the checking.

2. Introduce Lesson 1 on Teaching Students to Chart.

Day 3

1. Review timing and checking procedures.
2. Give timings.
3. Teach Lesson 2 on Teaching Students to Chart.
4. Explain procedure for finding practice sheets in Materials Box.

Day 4

1. Follow timing and checking procedures.
2. Teach Lesson 3 on Teaching Students to Chart.
3. Review procedure for finding practice sheet.

Day 5

1. Follow timing and checking procedures.
2. Review all charting procedures. Have students chart all five of their scores for the week on the AC-4 chart.
3. Have students turn in charts for teacher review. After the teacher reviews the charts, students can be pinpointed that are having difficulty. The teacher or charting monitors can give further assistance to these students.

Day 6

1. Follow timing, checking and charting procedures.
2. Introduce decision-making - see page 64, #8.

Adapted from the Precision Teaching Project Training Manual, Great Falls Public Schools, Great Falls, Montana.

INTRODUCTION TO STUDENTS

To introduce Precision Teaching to students, first discuss the meaning of the word precision. Explain that the root word precise means accurate or doing work the right way. In Precision Teaching, we go beyond just doing work accurately we add the importance of also doing it quickly. Use the example of two students - Bonnie and Clyde. Bonnie completes her math sheet with 100% in 5 minutes, while Clyde also completes his math sheet with 100%, but it takes him 20 minutes. Let the students determine which student is the more proficient learner, in other words which student knows the material the best. Explain further that if a student knows something well, he/she knows it at a good rate. This rationale aids the students in understanding why you are requiring them to do timings. Remind the students that daily practice will help improve their rates. "How do you get better at performing a task?" . . . PRACTICE.

TOOL SKILLS

Before the students do their timing it is best to explain the meaning of tool skills. For example, in math timings, writing digits is an important basic skill if they are to write answers fast. For reading, saying the alphabet or easy words fast is necessary to say higher level words at a faster rate. Give the students practice with their tool skills each day and continue until proficiency is reached. Students will enjoy the tool skill timings and see the practice as a fun game.

GLOSSARY*
Definition of Terms

AIM	An ending goal usually expressed as a specific frequency.
BEST FIT LINE OR LEARNING LINE	A line drawn through a series of data plots on the chart in order to determine the rate of change and direction of behavior.
CELERATION OR LEARNING	A method of measurement used in determining behavior change. It is usually expressed as movements per minute per week. If the behavior is increasing, it is called times (X) celeration. If the behavior is decreasing, it is called divide by (\div) celeration.
FREQUENCY OR RATE	A basic unit of measurement indicating the number of movements divided by a unit of time.
LEARNING OPPORTUNITY	An expression used in place of the term "error." It is indicated on the chart by (X).
LEARNING CHANNELS	The way in which the individual receives the individual, cue or signal; processes it; and responds. For example, with see/write channel, the student sees the cue and writes the answer.

MEDIAN (M)	The middle score of a group of scores when listed in sequential order.
PHASE OR CHANGE LINE	A curricular and/or environmental change indicated by drawing a vertical line one-half day before change.
PINPOINT	A specific behavior chosen to measure, e.g., add facts 0-10; oral reading speed; history facts.
PROBE	A practice skill sheet used specifically for timings to measure skill proficiency.
PRECISION TEACHING	A set of procedures that is based on direct, and daily measurement.
PROFICIENCY	A performance level believed to be necessary in order to assure generalization and maintenance of behavior.
SLICE BACK	A process by which the complexity or amount of curriculum material is made easier for the student to perform.

STANDARD
BEHAVIOR
CHART

A semi-logarithmic chart that allows us to record human behavior that occurs as infrequently as once per day (.001) to as often as 1,000 per minute. Twenty weeks or one school semester can be recorded on one chart.

TOOL SKILL

Any basic skill which is a prerequisite for the development of another skill.

*Adapted from the Precision Teaching Project Great Falls Public Schools, Great Falls, Montana